

I nastri di raccolta MC29/MC35 vengono installati in varie configurazioni sulle linee di accoppiatura MC2000/MESL, MC2000/MEWL – MC2001/MESL, MC2001/MEWL per raccogliere cartoni accoppiati in pacchetti.

The MC29/MC35 collecting belts are installed in many configuration of the MC2000/MESL, MC2000/MEWL–MC2001/MESL, MC2001/MEWL laminator lines to collect products in packets.

		MC29		MC35	
<b>SPESSORE, LUNGHEZZA E LARGHEZZA MASSIMI DELL'ACCOPIATO DA RACCOGLIERE</b>	<b>S<sub>max</sub></b>	6 mm <sup>(1)</sup>	15/64" <sup>(1)</sup>	6 mm <sup>(1)</sup>	15/64" <sup>(1)</sup>
	<b>L<sub>max</sub></b>	860 mm <sup>(1)</sup>	33 27/32" <sup>(1)</sup>	1040 mm <sup>(1)</sup>	40 15/16" <sup>(1)</sup>
	<b>W<sub>max</sub></b>	600 mm <sup>(1)</sup>	23 5/8" <sup>(1)</sup>	740 mm <sup>(1)</sup>	29 1/8" <sup>(1)</sup>
<b>VELOCITA' DI PRODUZIONE FINO A: SPEED UP TO:</b>		52 cicli/min <sup>(1)</sup>	52 cycles/min <sup>(1)</sup>	52 cicli/min <sup>(1)</sup>	52 cycles/min <sup>(1)</sup>
<b>POTENZA ISTALLATA ELECTRICAL POWER</b>		0.2 kW	0.27 hp	0.5 kW	0.67 hp
<b>PESO NET WEIGHT</b>		130 kg	290 lb	180 kg	390 lb

- (1) La velocità di produzione massima ed i limiti di prodotto raggiungibili dipendono da diversi fattori tra cui: la tipologia e le caratteristiche dei materiali usati (carta, cartone e collante), la formazione del personale addetto ed il formato del prodotto in lavorazione.  
The maximum production speed and the reachable product limits depend upon various factor including: the type and specifications of the materials used (paper, cardboard and glue), personnel training and size of the product being processed.

Le caratteristiche possono essere modificate senza preavviso.  
Technical specifications are subject to change without prior notice.

**MC29/MC35**  
**Vista del nastro di raccolta/ Picture of the collecting belt**



**MC29**  
**Layout e Ingombri**  
**Layout and Overall Dimensions**

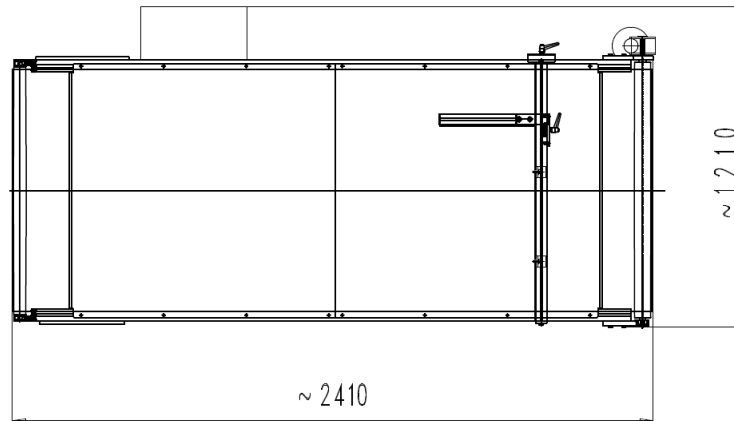
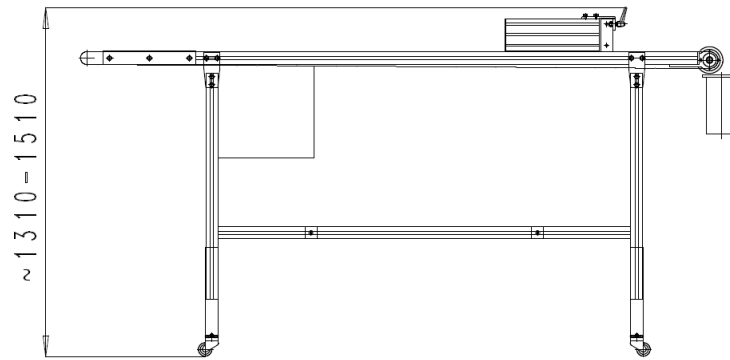

**MC35**  
**Layout e Ingombri**  
**Layout and Overall Dimensions**

